

AQVL/AQVH 85-140

Air Cooled Water Chillers Cooling Only
and Heat Pump
Engineering Data Manual



83 to 137 kW



92 to 147 kW



High Performance Components



Special inverter fan
(option)



pCO1 control and PGD user interface



3 pump option
Energy saving in partial load

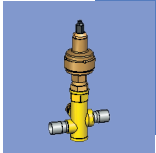

EXV
Optimization of superheating

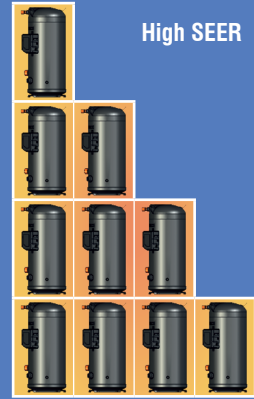

High SEER

100% 75% 50% 25%

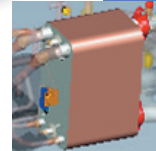

True dual circuit evaporator
Optimized heat transfer coefficient

800 mm, 6 poles, axial fans



Blue fin coil as standard on HP models



Compressor box
Standard on all units

360° accessible compressor box for maintenance

Oustanding Strength Points

- Units with **R410A refrigerant**. As near azeotropic mixture it behaves like a homogeneous substance (**reduced service problems in case of leakage or re-charge**) with negligible temperature glide.
Refrigerant with superior thermo-dynamical proprieties compared to R22 and R407C, it allows to have more efficiency or compact and lighter systems and larger operating limits (T ambient = -15 °C in heating mode).
- **2 independent refrigerant circuits** with 2 scroll compressors for each circuit.
- **Bi-flow electronic expansion devices** on all units : superheating value controlled by microprocessor, simple and accessible refrigeration system especially for heat pump versions with reduction of brazing points and then possible leakage.
- **V-shape condenser coils** ensuring compactness and small foot print.
- **High EER and COP** for fan coil application (water 12/7 °C cooling, 40/45 °C heating).
- **Excellent EER and COP** for floor heating application (water 23/18 °C cooling, 30/35 °C heating).
- **High SEER.**
- **2 acoustic versions** : STD (Standard) and S (Super Low Noise).
- **Heat recovery option** with desuperheater and total heat recovery.
- **Large choice of optional hydro kits** with or without buffer tank fitted on board of the chiller to perform package solution and plug & play concept.
- **Electric heaters fitted inside buffer tank** to ensure extra heating.
- For safety purpose when performing service operation, special valves dedicated to R410A are supplied on the refrigerant system. These valves, of 5/16" flare SAE type, are mounted on the liquid line and on the gauges manifold of the unit.

Specifications

General

The new **AQVL/AQVH** units have been designed to operate with **HFC 410A** refrigerant. Both compressors and heat exchangers (plate heat exchanger and coils) have been optimized for this refrigerant.

All the units are available either in **cooling only** or **heat pump** version. Each unit consists of **two independent refrigerant circuits** and is complete with high efficient and advanced technology components :

- Hermetic **Scroll** compressors with high efficiency and low vibration emissions,
- **Electronic expansion valves**,
- **"True dual"** circuit plate heat exchanger,
- Quiet fans located in externally mounted **nozzle profile housing** generating low sound levels,
- Controller using a **state-of-the-art microprocessor**.

The AQVL/AQVH units are available in **6 sizes and 4 versions** :

- **STD (Standard) version** : Designed in accordance with specifications described in the following sections.
- **HSE (High Seasonal Efficiency) version** : It has same equipment as that of the STD version, except that the units are equipped with **special inverter fans**, of large diameter, driven by **EC (electronic brushless type)** motors with **integrated electronic inverter**, to ensure low energy consumption.
- **HT (High Temperature) version** : It has same equipment as HSE units, but the **special inverter fans and motors** have a different regulation.
- **HPF (High Pressure Fan) version** : It has same equipment as STD units, except that the units are equipped with **special inverter fans** (same as those used on HSE version, but with a different regulation) driven by **EC motors** with **integrated electronic inverter**. The HPF version provides external static pressure up to **120 Pa**.

The STD and HSE versions can be supplied with **2 acoustic options** :

- **Standard (STD)** : The units are equipped with **star or delta connected fan motors** depending on size. The chillers are not supplied with fan speed controller, but fitted with **compressors box** to reduce the noise emissions.
- **Super Low Noise (S)** : The units are equipped with **star connected fan motors**, fitted with a speed controller which allows the units to operate with a very low rpm. The chillers are supplied with **compressors box** and **soundproof jackets** on compressors reducing significantly the noise emissions.

On the other hand, the HT and HPF versions can be supplied with STD option only.

In addition, all the units can be supplied with **2 heat recovery options** :

- **Desuperheater** : All the versions can be supplied with plate type heat exchangers fitted, one on each refrigerant circuit, on the compressor discharge line to recover about **20 % of the total heat** rejected to the condensers.
- **Total heat recovery (AQVR units)** : All the versions of the **cooling only** units can be supplied with a double circuit plate type heat exchanger to recover **100 % of heat rejection** by the condensers. 4-way valves and a field installed control sensor are also provided to ensure the cooling/heat recovery mode changeover.

Cabinet and structure

The cabinet and structure are made of heavy gauge galvanized steel. **All galvanized steel components are individually painted** by a special painting process before the assembly of the unit. This painting system performs a homogeneous protection to the corrosion.

The painting is a polyester powder based type, coloured in **RAL 9001**.

The units are suitable for outdoor installation, directly on the building roof or at the ground level.

Refrigerant circuits

All the units are composed of two independent and separate refrigerant circuits, complete with 4 hermetic scroll compressors in tandem configuration for each circuit.

Each refrigerant circuit is equipped with liquid line and discharge line shut-off valves, filter-drier with solid core, sight glass and **electronic expansion valve (EXV)**.

The heat pump units (AQVH) are provided with 4-way reversing valves, suction accumulators and liquid receivers on the liquid lines.

The AQVL and AQVH units are both provided with double-circuit plate heat exchangers, of "true dual" type.

The total heat recovery units are supplied with double-circuit water condenser (of plate heat exchanger type), 4-way reversing valves and liquid receivers downstream of the heat recovery condenser.

The functional diagram of each circuit is shown in the section "Refrigerant flow diagram".

Specifications (continued)

Compressors

Each unit is equipped with 4 hermetic scroll compressors arranged in tandem configuration per refrigerant circuit.

The compressors are fitted with an electronic control device which ensures protection of compressors against :

- overheating and overloading,
- reversal rotation and phase loss.

All compressors have direct-on-line starting and are mounted on rubber vibration isolators in order to minimize noise and vibration transmission.

Evaporator

Evaporator is of a "Dual Circuit" brazed stainless steel plate type heat exchanger. It is insulated with a 19 mm thick closed cell polyethylene foam material and is fitted with a film type electric heater on the external surface to prevent the unit from freezing at a low temperature (down to -18 °C) when the unit is off.

Condenser coils

The condenser coils are made of seamless copper tubes, arranged in staggered rows, mechanically expanded into corrugated aluminum fins.

They are mounted in V-shape arrangement, allowing the unit to be compact with small foot print.

The coils are supplied with blue fins on AQVH units to facilitate the flowing of water droplets during defrost cycles.

Condenser fans

All acoustic versions (STD & S) are equipped with large diameter, direct drive axial type fans with asynchronous three-phase motors.

Fans are fitted with externally mounted nozzle profile housing which generates low sound levels.

Fan speed control

The airflow is controlled in order to operate at a low ambient temperature.

On standard unit equipped with axial fans, the air flow control is :

- step type for STD version without fan speed controls, achieved by switching off some fans of each circuit in function of condensing pressure corrected by external temperature.
- stepless type for S version, achieved by an electronic fan speed control, supplied as standard, in function of condensing pressure.

The pressure actuated stepless type fan speed controller can be supplied as optional on STD version. It allows the units to operate in cooling mode at ambient temperature down to -18 °C.

Electrical board

The electrical board is located in a metal case arranged outside the unit and protected by a vertically pivoted access door. The metal case has an IP54 protection rating and is complete with grilles for natural air ventilation.

Electronic control

The units are supplied with the new microprocessor-based electronic control and management system ensuring the following functions :

- Management of the operation of compressors :
 - a) Power on/off
 - b) Anticycle management
 - c) Tandem unloading for high pressure or high compressor pressure ratio (integrated inside the curves of compressor operating limits).
- Chilled and hot water temperature regulation (control option on inlet water temperature RWT (PID) or outlet water temperature LWT (neutral band type) of the evaporator.
- Control of superheating on suction line.

- Evaporator antifreeze protection.
- Heat pump defrost control for automatic operation.
- Management of high and low pressure alarms.
- Management of the electronic expansion valves by means of EXV controller allowing optimized functions : cooling, heating, start-up and defrost.
- Management of external interlocks.
- Management of the remote control :
 - d) Unit power on/off
 - e) Summary alarm signals
- Remote signalling, by dry contacts :
 - f) Voltage presence
 - g) Compressors in operation
 - h) Circuit alarm unit
- Management of the hydro kit : start-up of pump, antifreeze heater of external tank.
- Management of the heat recovery mode by means of inlet water temperature sensor at the heat recovery condenser.

The unit controller can also clearly show all control parameters of the machine on the liquid crystal display, such as :

- Display of superheating value.
- Display of the temperature at the evaporator inlet and outlet.
- Display of the ambient air temperature.
- Display of the circuit 1 and circuit 2 discharge pressure and suction pressure.
- Display of the set point.
- Display of opening steps of EEV.
- Display of speed control signal (voltage) of fans.
- Display of the various alarm and operation status :
 - i) Compressor start-up alarm (discharge pressure check)
 - j) Low / High pressure
 - k) Low / High super-heating
 - l) Evaporator antifreeze
 - m) Flow switch signal for lack of water
 - n) Control of the compressor operating hours
 - o) Compressors in operation
 - p) Pump in operation and operating hours
 - q) Thermal protection of compressors
 - r) Thermal protection of fans
 - s) Faulty sensors

Control and safety devices

Each unit is fitted with the following devices :

Safety :

- Power disconnect switch with an emergency stop function.
- HP switches (double on each circuit), set to 40.5 bar, automatic reset and manual reset from the control panel.
- Flow switch on the evaporator side.
- Antifreeze temperature sensor (set to +4 °C) on the evaporator (AQLV/AQVH only).
- Safety valve on the discharge line and the liquid receiver (on AQVH), set to 45 bar.

Specifications (continued)

Control :

- HP and LP transducers (two for each circuit).
- Evaporator water inlet temperature sensor.
- Evaporator water outlet temperature sensor (with an antifreeze function).
- Suction temperature sensor for EXV control.
- Ambient air temperature sensor.
- Coil temperature sensors.
- Heat recovery condenser temperature sensor (AQVR only).

Conformity with standards

The following applies to all the sizes and versions of AQVL/AQVH/AQVR units :

- ✓ Machine Directive : 2006/42/EC
- ✓ Low Voltage Directive : 2006/95/EC
- ✓ Electromagnetic Compatibility Directive : 2004/108/EC
- ✓ Pressure Equipment Directive : 97/23/EC

Standard equipment

- ✓ Back light display.
- ✓ Digital pressure and temperature reading kit.
- ✓ High ambient pressure control.
- ✓ Double set point (AQVL/AQVH only).
- ✓ Sequence phase control.
- ✓ Electronic expansion valves.
- ✓ Control circuit transformer 400 V/230 V.
- ✓ Data logger.
- ✓ Power supply single point box.
- ✓ Power supply without neutral.
- ✓ Hour meter.
- ✓ Main switch.
- ✓ Refrigerant R410A.
- ✓ PED approval.
- ✓ Blue fin coils (AQVH only).
- ✓ Evaporator antifreeze electric heater.
- ✓ Compressor jacket (S version only).
- ✓ Compressor box.
- ✓ Rubber anti-vibration pads.

Optional hydro kits

All hydro kits are supplied fitted inside the unit with or without buffer tank. They are available for AQVL and AQVH units only.

- **1P** : 1 low or high pressure pump kit with relevant accessories.
- **2P** : 2 low or high pressure pump kit with relevant accessories.
- **3P** : 3 low or high pressure pump kit with relevant accessories.
- **1P+T** : 1P kit + buffer tank covered with insulation and fitted with an antifreeze electric heater.
- **2P+T** : 2P kit + buffer tank covered with insulation and fitted with an antifreeze electric heater.

When thermodynamic heating is not sufficient, optional electric heaters can be provided inside buffer tank to ensure extra heating.

Factory-installed options

- ✓ ModBus protocol kit for BMS.
- ✓ Lonwork protocol kit for BMS.
- ✓ Bacnet protocol kit for BMS.
- ✓ WEBctrl.
- ✓ Ethernet TCP/IP interface board.
- ✓ Compressor soft starter.
- ✓ Pressure actuated stepless fan speed controller for low ambient operation (-18 °C) (STD version).
- ✓ Power factor correction capacitors.
- ✓ Compressor overload protection.
- ✓ Automatic circuit breaker.
- ✓ GSM.
- ✓ HP & LP manometers.
- ✓ Condenser coils with "Fin Guard Silver" (polyurethane) treatment.
- ✓ Condenser coils with copper fins.
- ✓ Condenser coils with black epoxy treatment.
- ✓ Coil guards.
- ✓ Chiller grilles.
- ✓ Compressor jacket.
- ✓ Total heat recovery (AQVR).
- ✓ Desuperheater.
- ✓ On board hydro kits.
- ✓ Electric heaters inside buffer tank, used as extra heating.
- ✓ Automatic pump switch on 2 pump kit.
- ✓ Antifreeze electric heater for hydraulic manifolds.

Field-installed accessories

- ✓ Remote keyboard panel.
- ✓ Master and slaves control, up to 4 units max.
- ✓ Chiller grilles.
- ✓ Pressure switch.
- ✓ Water filter.

Refrigerant Flow Diagram - AQVH Units

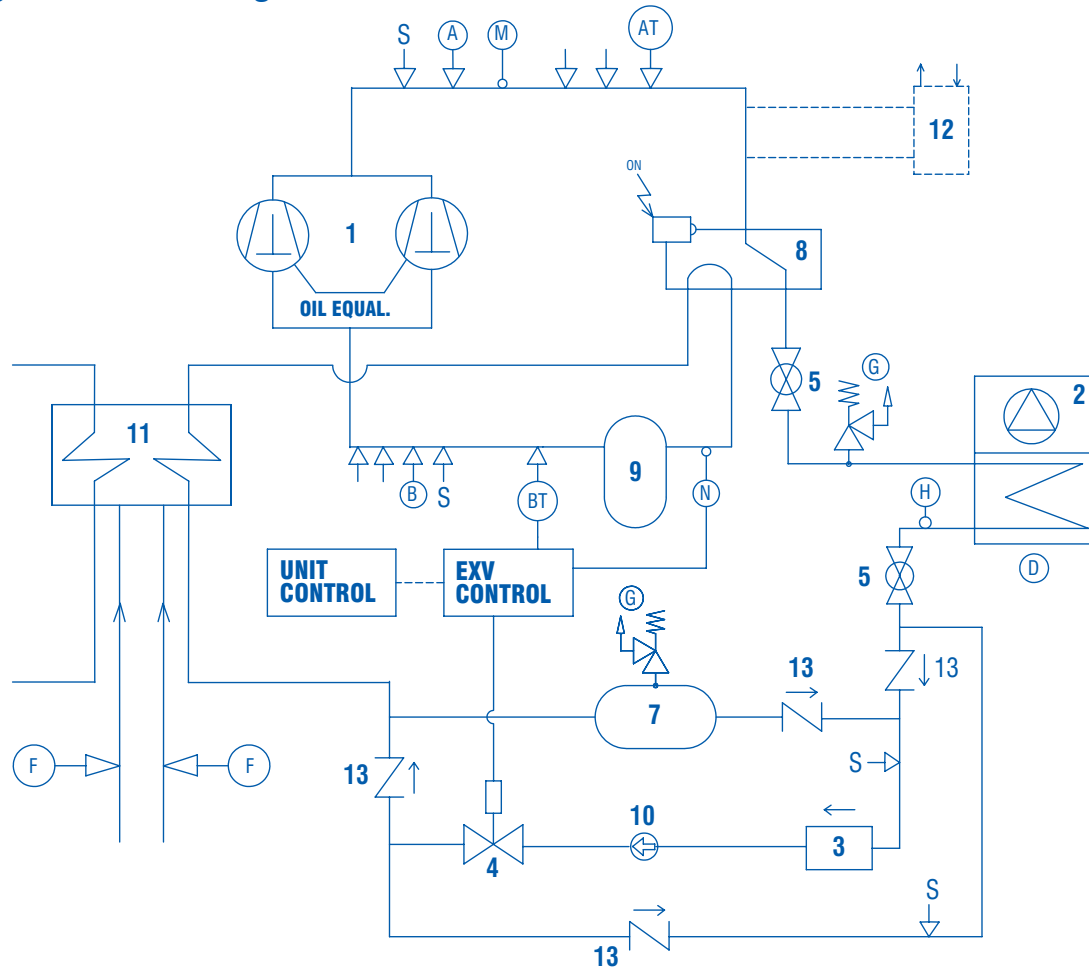

COMPONENTS

- 1** Compressor tandem scroll type
- 2** Air cooled condenser
- 3** Filter drier
- 4** Electronic expansion valve
- 5** Globe valve
- 7** Liquid receiver
- 8** Four-way valve
- 9** Suction accumulator
- 10** Sight glass
- 11** Plate heat exchanger (Dual type)
- 12** Desuperheater (optional)

SAFETY/CONTROL DEVICES

- A** High pressure switch
- AT** High pressure transducer
- B** Low pressure switch (1.5 bar)
- BT** Low pressure transducer
- FS** Water flow switch
- D** Air temperature sensor
- E** Outlet water temperature sensor
- F** Inlet water temperature sensor
- G** PED pressure relief valve
- H** Defrost temperature sensor
- M** Discharge temperature sensor
- N** Suction temperature sensor
- S** 5/16" schrader connection (service only)
- ↓ Pipe connection with schrader valve

Note: For reasons of readability, one circuit only is shown. The second circuit is identical.

Operating Limits

AQVL/AQVH 85 to 140 - R410A - STD/S Version - Cooling

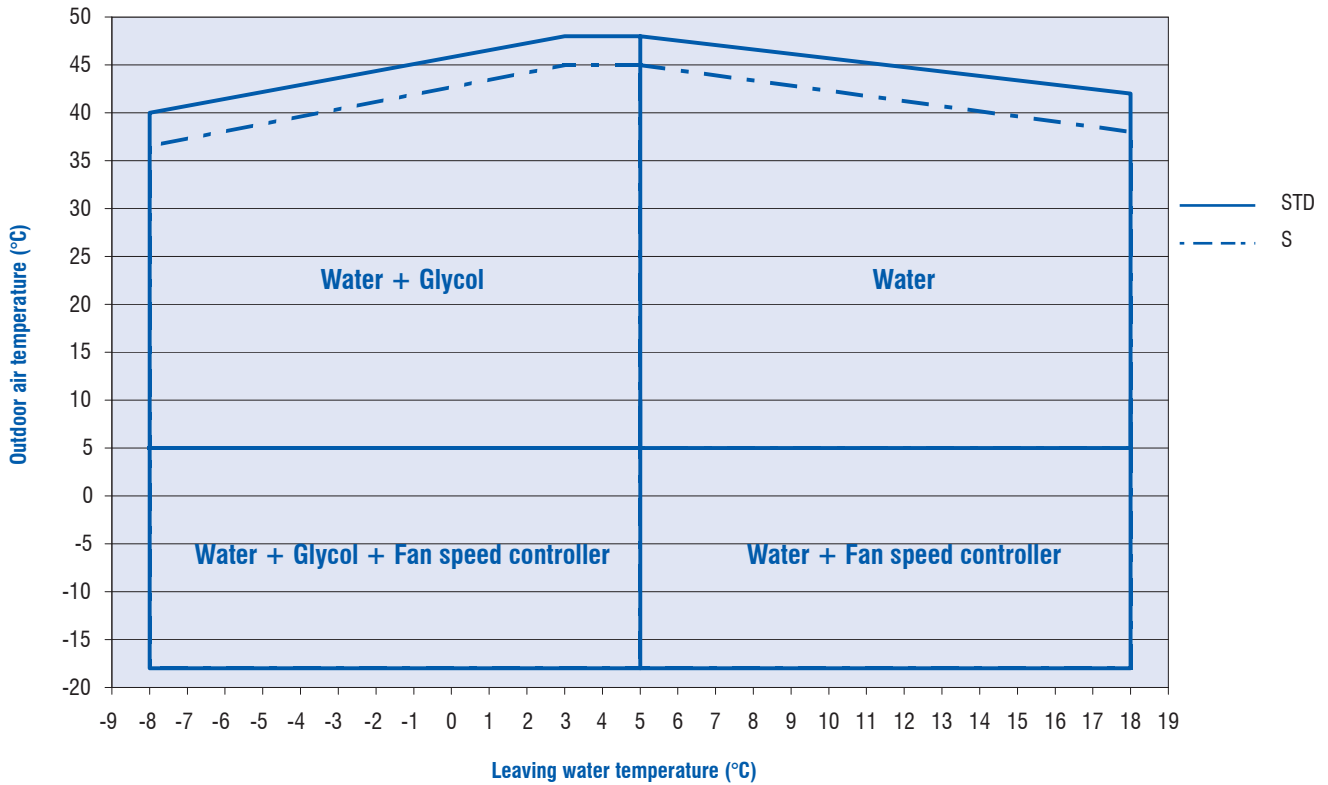

Notes :

Operating limits are referred to full load (4 compressors running).
 Maximum %glycol (ethylenic or propilenic) : 40%

AQVL/AQVH 85 to 140 - R410A - HSE/HT Version - Cooling

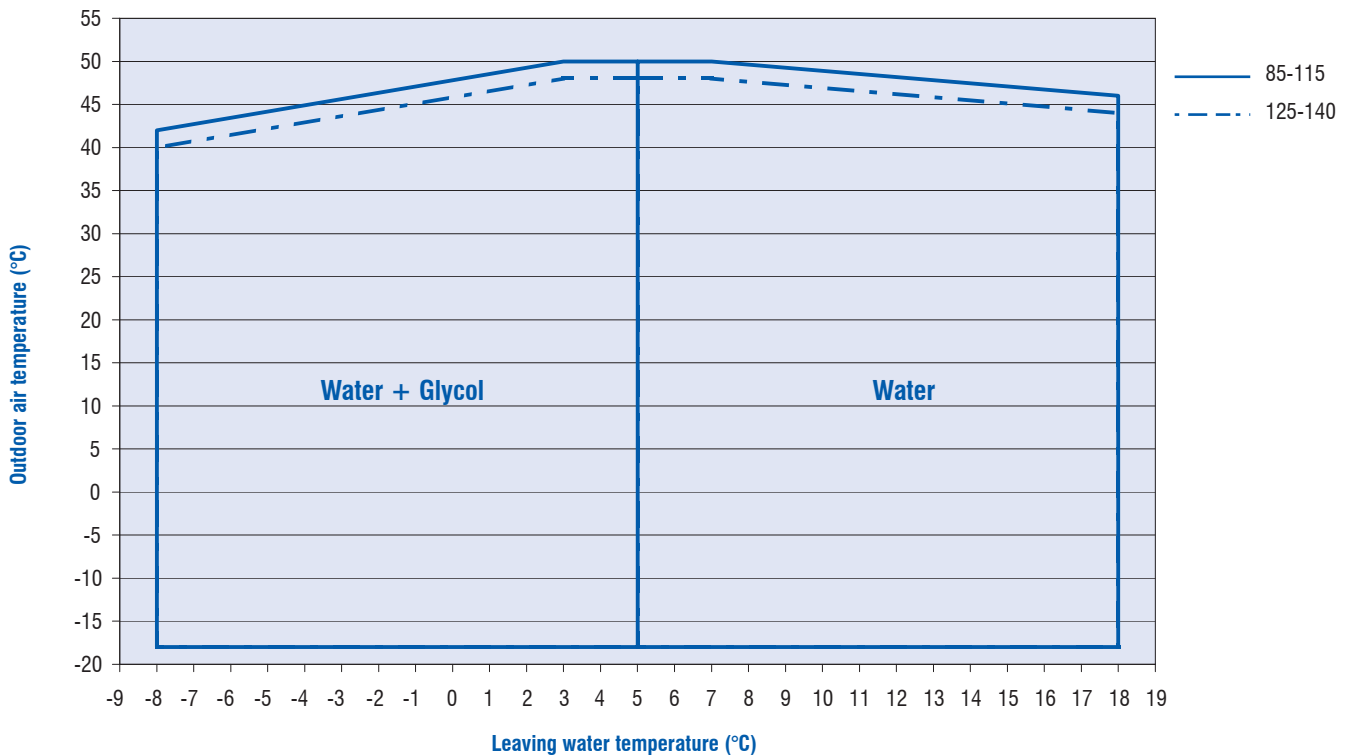

Notes :

Operating limits are referred to full load (4 compressors running).
 Maximum %glycol (ethylenic or propilenic) : 40%

Operating Limits (cont)

AQVL/AQVH 85 to 140 - R410A - STD/HSE/HT/S Version - Heating

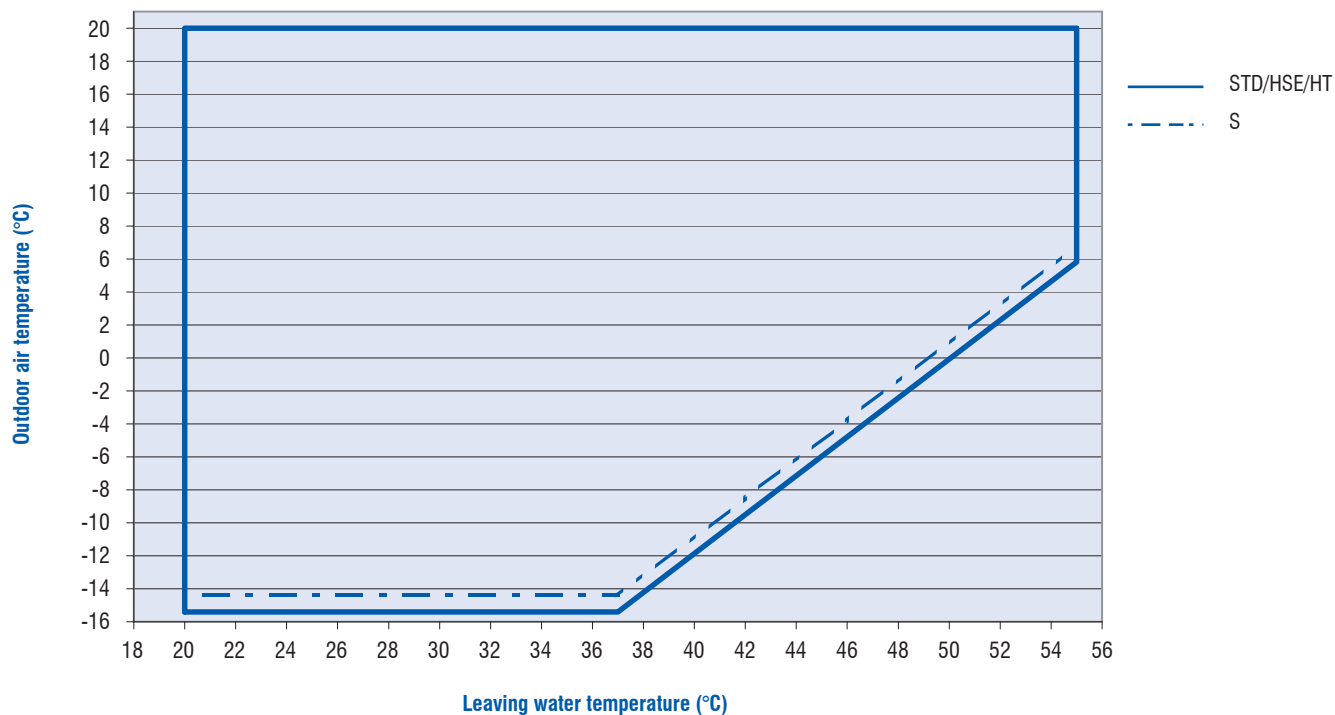

Notes :

Operating limits are referred to full load (4 compressors running).

Maximum %glycol (ethylenic or propilenic) : 40%

Technical Data - AQVH 85 to 140 - R410A - STD/HSE - S Version

AQVH Sizes - STD/HSE - S Version		85	95	105	115	125	140
Cooling Capacity (1)	kW	78,4	86,7	95,1	102	112	124,6
Input Power (Compressor) (1)	kW	28,6	33,2	36	39,1	43,1	47,6
Total EER / Energy efficiency class (1)		2,75/C	2,61/D	2,64/D	2,62/D	2,61/D	2,63/D
SEER / η_{sp} (2)		4,25/167	4,68/184	4,63/182	4,17/164	4,33/170	4,28/168
Total EER / Energy eff. class (HSE) (1)		2,84/C	2,69/D	2,71/C	2,69/D	2,65/D	2,67/D
SEER (HSE) / η_{sp} (HSE) (2)		4,6/181	5,03/198	4,95/195	4,55/179	4,6/181	4,5/177
Heating Capacity (3)	kW	89,5	99,8	108	115	129	142
Input Power (Compressor) (3)	kW	26,4	30,1	32	34,7	39,3	43
Total COP (3)		3,39	3,32	3,36	3,32	3,29	3,3
Total COP (HSE) (3)		3,55	3,46	3,5	3,45	3,38	3,38
SCOP / η_{sp} (4)		3,61/141	3,64/143	3,78/148	3,77/148	3,47/136	3,54/139
Number of Refrigerant Circuits		2	2	2	2	2	2
Part Load Steps	%	0-25-50-75-100	0-25-50-75-100	0-24-47-74-100	0-25-50-75-100	0-22-43-72-100	0-25-50-75-100
Power Supply		400V/3/50Hz	400V/3/50Hz	400V/3/50Hz	400V/3/50Hz	400V/3/50Hz	400V/3/50Hz
Startup Type		Direct	Direct	Direct	Direct	Direct	Direct
REFRIGERANT							
Type		R410A					
Charge	kg	20,4	22,6	24,7	26,7	29,2	32,5
COMPRESSOR							
Number		4	4	4	4	4	4
Type		Scroll	Scroll	Scroll	Scroll	Scroll	Scroll
Crankcase Heater	W	90	90	90	90	90	90
EVAPORATOR							
Number		1	1	1	1	1	1
Type		Plate	Plate	Plate	Plate	Plate	Plate
Water flow Rate	l/h	13496	14924	16355	17632	19349	21508
Water Pressure Drop	kPa	Refer to evaporator water pressure drop curve					
Antifreeze Heater	W	130	130	130	130	130	130
DESUPERHEATER							
Number		2	2	2	2	2	2
Type		Plate	Plate	Plate	Plate	Plate	Plate
Heat recovery	kW	21,0	23,6	25,8	27,9	30,7	34,0
Water flow rate	l/h	3614	4056	4442	4801	5273	5854
Water Pressure Drop	kPa	Refer to desuperheater water pressure drop					
COIL							
Number		2	2	2	2	2	2
Frontal Surface	l x a	2000 x 1200	2000 x 1200	2000 x 1200	2000 x 1200	2600 x 1200	2600 x 1200
FANS							
Number		2	2	2	2	2	2
Air Flow Rate	m ³ /h	25800	25800	25300	24800	36900	35800
Speed	rpm	500	500	500	500	690	690
Input Power	kW	1,8	1,8	1,8	1,8	2,1	2,1
Input Power HSE	kW	0,6	0,6	0,6	0,6	1,2	1,2
WATER CONNECTIONS (EVAPORATOR)							
Type		Male GAS Threaded					
Inlet Diameter	inch	2"1/2	2"1/2	2"1/2	2"1/2	2"1/2	2"1/2
Outlet Diameter	inch	2"1/2	2"1/2	2"1/2	2"1/2	2"1/2	2"1/2
WATER CONNECTIONS (DESUPERHEATER)							
Type		Male GAS Threaded					
Inlet Diameter	inch	1"	1"	1"	1"	1"	1"
Outlet Diameter	inch	1"	1"	1"	1"	1"	1"
WEIGHT							
Shipping Weight	kg	1095	1110	1152	1183	1226	1300
Operating Weight	kg	1120	1135	1179	1210	1257	1331
DIMENSIONS							
Length	mm	2555	2555	2555	2555	3155	3155
Width (transport only)	mm	1095 (1250)	1095 (1250)	1095 (1250)	1095 (1250)	1095 (1250)	1095 (1250)
Height	mm	2185	2185	2185	2185	2185	2185
ACOUSTIC DATA							
Sound Power Level (5)	dB(A)	82	82	82	82	86	86
Sound Pressure Level (6)	dB(A)	50	50	50	50	54	54

- (1) According EN14511: chilled water inlet/outlet temperature: 12/7°C, outdoor ambient temperature 35°C DB.
- (2) According EN14825 and following COMMISSION REGULATION (EU) No 2016/2281 for comfort application chillers <400kW.
- (3) According EN14511: warm water inlet/outlet temperature: 40/45°C, outdoor ambient temperature 7°C DB/6°C WB.
- (4) According EN14825 and Following COMMISSION REGULATION (EU) No 813/2013 for low-temperature heat pumps.
- (5) Sound levels are at fully loaded conditions. Sound power level values refers to ISO 3744 standard.
- (6) Sound pressure calculated at 10 m. Sound pressure levels refer to ISO standard 3744 with parallelepiped shape.

Performance Data - AQVL 85 to 140 - R410A - STD/HSE - S Version

AQVL Sizes S Version	LWT (°C)	Outdoor air temperature (°C)															
		25		30		32		35		38		40		42		45	
		P cool (kW)	P abs* (kW)	P cool (kW)	P abs* (kW)	P cool (kW)	P abs* (kW)	P cool (kW)	P abs* (kW)	P cool (kW)	P abs* (kW)	P cool (kW)	P abs* (kW)	P cool (kW)	P abs* (kW)	P cool (kW)	P abs* (kW)
AQVL 85	5	84.5	20.9	80.5	23.1	79.0	24.1	76.5	25.6	73.6	27.1	71.5	28.2	69.3	29.3	66.1	31.1
	7	89.3	21.4	85.1	23.6	83.5	24.5	80.9	26.0	77.8	27.6	75.6	28.6	73.4	29.8		
	9	93.5	21.7	89.2	23.9	87.5	24.9	84.8	26.4	81.7	27.9	79.5	29.0	77.2	30.1		
	11	98.1	22.1	93.6	24.3	91.9	25.3	89.0	26.8	85.8	28.3	83.5	29.4				
	13	103.1	22.6	98.4	24.8	96.6	25.8	93.7	27.3	90.3	28.8	88.0	29.9				
	15	108.6	23.1	103.7	25.4	101.8	26.3	98.7	27.8	95.3	29.4						
	18	117.4	24.1	112.0	26.3	109.9	27.3	106.3	28.8	101.9	30.2						
AQVL 95	5	94.4	24.4	90.0	27.0	88.2	28.1	85.4	29.9	82.2	31.7	79.8	33.0	77.4	34.3	73.8	36.3
	7	99.7	24.9	95.1	27.5	93.3	28.6	90.3	30.4	86.9	32.2	84.5	33.4	82.0	34.8		
	9	104.4	25.4	99.6	27.9	97.8	29.0	94.7	30.8	91.2	32.6	88.8	33.9	86.2	35.2		
	11	109.5	25.8	104.6	28.4	102.6	29.5	99.4	31.3	95.9	33.1	93.3	34.3				
	13	115.1	26.4	109.9	29.0	107.9	30.1	104.7	31.8	100.9	33.6	98.2	34.9				
	15	121.3	27.0	115.8	29.6	113.7	30.7	110.3	32.5	106.4	34.3						
	18	131.1	28.2	125.1	30.8	122.7	31.9	118.7	33.6	113.8	35.3						
AQVL 105	5	103.1	26.8	98.3	29.6	96.4	30.8	93.3	32.8	89.8	34.7	87.2	36.1	84.6	37.5	80.7	39.8
	7	108.9	27.3	103.9	30.1	101.9	31.4	98.7	33.3	95.0	35.3	92.3	36.6	89.6	38.1		
	9	114.1	27.8	108.9	30.6	106.8	31.8	103.5	33.8	99.7	35.7	97.0	37.1	94.2	38.5		
	11	119.7	28.3	114.3	31.1	112.1	32.3	108.7	34.3	104.7	36.3	101.9	37.6				
	13	125.8	28.9	120.1	31.7	117.9	33.0	114.4	34.9	110.2	36.9	107.3	38.2				
	15	132.5	29.6	126.6	32.4	124.2	33.7	120.5	35.6	116.3	37.6						
	18	143.2	30.8	136.7	33.7	134.1	34.9	129.7	36.8	124.3	38.6						
AQVL 115	5	110.6	29.3	105.4	32.4	103.4	33.7	100.1	35.8	96.3	38.0	93.6	39.5	90.8	41.1	86.5	43.5
	7	116.8	29.9	111.4	33.0	109.3	34.3	105.8	36.4	101.9	38.6	99.0	40.1	96.1	41.7		
	9	122.3	30.4	116.8	33.5	114.6	34.8	111.0	36.9	106.9	39.1	104.0	40.6	101.0	42.1		
	11	128.4	30.9	122.6	34.0	120.2	35.4	116.6	37.5	112.3	39.7	109.3	41.2				
	13	134.9	31.6	128.8	34.7	126.5	36.1	122.7	38.2	118.2	40.3	115.1	41.8				
	15	142.2	32.4	135.8	35.5	133.2	36.9	129.2	39.0	124.7	41.1						
	18	153.7	33.7	146.6	36.9	143.8	38.2	139.1	40.3	133.4	42.3						
AQVL 125	5	124.8	31.1	119.0	34.3	116.7	35.8	113.0	38.0	108.7	40.3	105.6	41.9	102.5	43.5	97.7	46.1
	7	131.9	31.7	125.8	34.9	123.4	36.4	119.5	38.6	115.0	40.9	111.8	42.5	108.5	44.1		
	9	138.1	32.2	131.8	35.5	129.3	36.9	125.3	39.1	120.7	41.4	117.4	43.0	114.1	44.7		
	11	144.9	32.8	138.4	36.1	135.7	37.5	131.6	39.8	126.8	42.0	123.4	43.6				
	13	152.3	33.5	145.4	36.8	142.8	38.2	138.5	40.4	133.5	42.7	130.0	44.3				
	15	160.5	34.3	153.3	37.6	150.4	39.1	145.9	41.3	140.8	43.6						
	18	173.5	35.8	165.5	39.1	162.4	40.5	157.0	42.7	150.5	44.8						
AQVL 140	5	139.6	35.3	133.1	39.0	130.6	40.7	126.4	43.2	121.6	45.8	118.1	47.6	114.6	49.5	109.2	52.5
	7	147.5	36.0	140.7	39.7	138.0	41.4	133.6	43.9	128.6	46.5	125.0	48.3	121.4	50.2		
	9	154.5	36.6	147.5	40.3	144.7	42.0	140.2	44.5	135.0	47.1	131.4	48.9	127.6	50.8		
	11	162.1	37.3	154.8	41.0	151.8	42.6	147.2	45.2	141.9	47.8	138.1	49.6				
	13	170.4	38.1	162.7	41.8	159.7	43.4	154.9	46.0	149.3	48.6	145.4	50.4				
	15	179.5	39.0	171.4	42.8	168.3	44.4	163.2	47.0	157.5	49.6						
	18	194.0	40.7	185.2	44.4	181.6	46.1	175.7	48.5	168.4	50.9						

(*) Compressors only
 LWT : Leaving water temperature

Performance Data - AQVH 85 to 140 - R410A - STD/HSE - S Version - Cooling

AQVH Sizes S Version	LWT (°C)	Outdoor air temperature (°C)															
		25		30		32		35		38		40		42		45	
		P cool (kW)	P abs* (kW)	P cool (kW)	P abs* (kW)	P cool (kW)	P abs* (kW)	P cool (kW)	P abs* (kW)	P cool (kW)	P abs* (kW)	P cool (kW)	P abs* (kW)	P cool (kW)	P abs* (kW)	P cool (kW)	P abs* (kW)
AQVH 85	5	82.1	21.4	78.3	23.6	76.8	24.6	74.3	26.2	71.4	27.7	69.3	28.8	67.2	29.9	64.0	31.7
	7	86.8	21.8	82.7	24.1	81.1	25.1	78.5	26.6	75.5	28.2	73.3	29.3	71.1	30.4		
	9	90.8	22.2	86.6	24.4	85.0	25.4	82.3	27.0	79.2	28.5	77.0	29.6	74.8	30.8		
	11	95.2	22.6	90.9	24.9	89.1	25.9	86.4	27.4	83.2	29.0	81.0	30.0				
	13	100.1	23.1	95.5	25.4	93.7	26.3	90.9	27.9	87.6	29.5	85.3	30.5				
	15	105.4	23.6	101.1	26.0	99.1	27.0	95.7	28.5	92.3	30.0						
	18	113.9	24.6	108.7	26.9	106.6	27.9	103.2	29.5	98.9	30.9						
AQVH 95	5	90.8	25.0	86.6	27.7	84.9	28.8	82.1	30.6	78.9	32.5	76.7	33.7	74.3	35.1	70.8	37.1
	7	95.9	25.5	91.5	28.2	89.7	29.3	86.8	31.2	83.5	33.0	81.1	34.3	78.7	35.6		
	9	100.4	25.9	95.8	28.6	94.0	29.8	91.0	31.6	87.6	33.4	85.1	34.7	82.7	36.0		
	11	105.3	26.4	100.5	29.1	98.6	30.3	95.5	32.1	92.0	33.9	89.5	35.2				
	13	110.7	27.0	105.6	29.7	103.6	30.8	100.5	32.7	96.9	34.5	94.3	35.8				
	15	116.5	27.7	111.8	30.4	109.5	31.6	105.9	33.4	102.0	35.2						
	18	125.9	28.8	120.1	31.5	117.9	32.7	114.1	34.5	109.4	36.2						
AQVH 105	5	99.5	27.4	94.9	30.3	93.0	31.5	90.0	33.5	86.5	35.5	84.0	36.9	81.5	38.3	77.6	40.6
	7	105.1	27.9	100.2	30.8	98.3	32.1	95.1	34.1	91.5	36.1	88.9	37.4	86.2	38.9		
	9	110.1	28.4	105.0	31.3	103.0	32.5	99.7	34.5	96.0	36.5	93.3	37.9	90.6	39.4		
	11	115.4	28.9	110.1	31.8	108.0	33.1	104.7	35.1	100.8	37.1	98.1	38.5				
	13	121.3	29.5	115.7	32.5	113.6	33.7	110.1	35.7	106.2	37.7	103.4	39.1				
	15	127.7	30.3	122.5	33.3	120.0	34.5	116.0	36.5	111.8	38.4						
	18	138.0	31.5	131.7	34.5	129.2	35.8	125.1	37.7	119.9	39.6						
AQVH 115	5	107.3	29.8	102.3	32.9	100.3	34.3	97.0	36.4	93.3	38.6	90.6	40.1	87.8	41.7	83.7	44.2
	7	113.3	30.4	108.1	33.5	105.9	34.9	102.5	37.1	98.6	39.2	95.8	40.8	92.9	42.3		
	9	118.7	30.9	113.2	34.0	111.0	35.4	107.5	37.6	103.5	39.8	100.6	41.3	97.7	42.9		
	11	124.4	31.5	118.7	34.6	116.5	36.0	112.8	38.2	108.7	40.4	105.8	41.9				
	13	130.8	32.1	124.8	35.3	122.4	36.7	118.7	38.8	114.5	41.0	111.5	42.5				
	15	137.7	32.9	132.1	36.2	129.4	37.6	125.1	39.7	120.6	41.8						
	18	148.8	34.3	142.0	37.5	139.3	38.9	134.8	41.1	129.2	43.1						
AQVH 125	5	117.8	32.8	112.2	36.2	110.0	37.7	106.5	40.1	102.4	42.5	99.4	44.2	96.4	45.9	91.8	48.6
	7	124.4	33.4	118.6	36.9	116.3	38.4	112.5	40.8	108.2	43.2	105.1	44.8	102.0	46.6		
	9	130.2	34.0	124.2	37.4	121.8	39.0	118.0	41.3	113.6	43.8	110.4	45.4	107.2	47.2		
	11	136.5	34.6	130.3	38.1	127.8	39.6	123.8	42.0	119.3	44.4	116.1	46.0				
	13	143.5	35.3	136.9	38.9	134.4	40.4	130.3	42.7	125.6	45.1	122.3	46.8				
	15	151.1	36.2	144.9	39.8	142.0	41.3	137.2	43.7	132.3	46.0						
	18	163.3	37.7	155.8	41.3	152.9	42.8	148.0	45.2	141.8	47.4						
AQVH 140	5	130.9	36.3	124.8	40.1	122.3	41.8	118.4	44.4	113.8	47.0	110.5	48.9	107.1	50.8	102.0	53.8
	7	138.3	37.0	131.8	40.8	129.2	42.5	125.0	45.1	120.3	47.8	116.9	49.6	113.4	51.6		
	9	144.8	37.6	138.1	41.5	135.4	43.1	131.2	45.8	126.2	48.4	122.7	50.3	119.1	52.2		
	11	151.8	38.3	144.8	42.2	142.1	43.9	137.6	46.5	132.6	49.1	129.0	51.0				
	13	159.5	39.1	152.2	43.0	149.4	44.7	144.8	47.3	139.7	50.0	136.0	51.8				
	15	167.9	40.1	161.1	44.1	157.9	45.8	152.6	48.3	147.1	51.0						
	18	181.5	41.8	173.2	45.7	169.9	47.4	164.5	50.0	157.6	52.5						

(*) Compressors only
 LWT : Leaving water temperature

Performance Data - AQVH 85 to 140 - R410A - STD/HSE - S Version - Heating

AQVH Sizes S Version	LWT (°C)	Outdoor air temperature (°C)															
		-7		-5		-3		0		5		7		10		15	
		Pheat (kW)	Pabs* (kW)	Pheat (kW)	Pabs* (kW)	Pheat (kW)	Pabs* (kW)	Pheat (kW)	Pabs* (kW)	Pheat (kW)	Pabs* (kW)	Pheat (kW)	Pabs* (kW)	Pheat (kW)	Pabs* (kW)	Pheat (kW)	Pabs* (kW)
AQVH 85	30	64.4	16.8	69.0	16.9	72.9	17.0	79.1	17.1	89.6	17.3	94.7	17.5	102.3	17.8	116.3	18.4
	35	63.8	18.9	68.3	18.9	72.1	19.0	78.1	19.1	88.2	19.3	93.0	19.5	100.3	19.7	113.9	20.3
	40	63.2	21.2	67.5	21.3	71.2	21.3	77.0	21.4	86.7	21.6	91.3	21.7	98.3	22.0	111.1	22.6
	45					70.2	24.1	75.8	24.1	86.4	24.7	89.5	24.4	96.2	24.6	108.4	25.2
	50							74.6	27.3	80.5	26.2	87.7	27.4	94.1	27.6	106.5	28.2
AQVH 95	30	71.8	19.3	77.0	19.4	81.3	19.5	88.3	19.6	100.0	19.9	105.6	20.1	114.1	20.4	129.8	21.2
	35	71.1	21.7	76.2	21.7	80.4	21.8	87.1	21.9	98.4	22.2	103.7	22.4	111.9	22.7	127.1	23.3
	40	70.5	24.4	75.3	24.4	79.4	24.5	85.8	24.6	96.7	24.8	101.8	25.0	109.7	25.2	123.9	26.0
	45					78.3	27.6	84.6	27.7	96.4	28.4	99.9	28.0	107.3	28.2	120.9	28.9
	50							83.2	31.3	89.8	30.1	97.8	31.5	104.9	31.7	118.8	32.3
AQVH 105	30	77.5	20.7	83.1	20.8	87.8	20.9	95.3	21.0	107.9	21.3	113.9	21.5	123.1	21.8	140.1	22.7
	35	76.8	23.2	82.2	23.3	86.7	23.3	94.0	23.5	106.2	23.7	111.9	23.9	120.8	24.2	137.1	24.9
	40	76.1	26.1	81.3	26.1	85.7	26.2	92.6	26.3	104.4	26.5	109.9	26.7	118.4	27.0	133.8	27.8
	45					84.5	29.6	91.3	29.6	104.1	30.4	107.8	29.9	115.9	30.2	130.5	30.9
	50							89.8	33.5	96.9	32.2	105.6	33.7	113.2	33.9	128.2	34.6
AQVH 115	30	82.9	22.5	88.9	22.6	93.9	22.7	101.9	22.9	115.5	23.2	121.9	23.4	131.8	23.8	149.8	24.7
	35	82.1	25.2	87.9	25.3	92.8	25.4	100.5	25.6	113.6	25.9	119.8	26.1	129.2	26.4	146.7	27.1
	40	81.4	28.4	86.9	28.5	91.6	28.6	99.1	28.7	111.7	28.9	117.6	29.1	126.6	29.4	143.1	30.3
	45					90.4	32.2	97.6	32.3	111.3	33.1	115.3	32.6	123.9	32.9	139.6	33.7
	50							96.0	36.5	103.7	35.0	112.9	36.7	121.1	36.9	137.2	37.7
AQVH 125	30	93.0	25.4	99.8	25.5	105.4	25.6	114.4	25.8	129.6	26.2	136.8	26.4	147.9	26.8	168.2	27.8
	35	92.2	28.5	98.7	28.6	104.1	28.7	112.8	28.8	127.5	29.2	134.4	29.4	145.0	29.8	164.7	30.6
	40	91.3	32.1	97.6	32.1	102.8	32.2	111.2	32.3	125.3	32.6	132.0	32.8	142.1	33.2	160.6	34.2
	45					101.5	36.3	109.6	36.4	124.9	37.3	129.4	36.8	139.1	37.1	156.6	38.0
	50							107.8	41.2	116.3	39.5	126.7	41.4	135.9	41.7	153.9	42.5
AQVH 140	30	102.1	27.9	109.5	28.0	115.6	28.1	125.5	28.3	142.1	28.7	150.1	29.0	162.2	29.4	184.5	30.6
	35	101.1	31.3	108.3	31.4	114.2	31.5	123.8	31.7	139.8	32.0	147.5	32.3	159.1	32.7	180.6	33.6
	40	100.2	35.2	107.0	35.3	112.8	35.4	122.0	35.5	137.5	35.8	144.8	36.0	155.9	36.4	176.2	37.5
	45					111.3	39.9	120.2	40.0	137.1	41.0	142.0	40.4	152.6	40.7	171.9	41.7
	50							118.3	45.2	127.6	43.4	139.1	45.5	149.1	45.7	168.9	46.7

(*) Compressors only

LWT : Leaving water temperature

Dimensions (mm) - AQVL/AQVH - R410A - Sizes 85 to 115

Bottom view

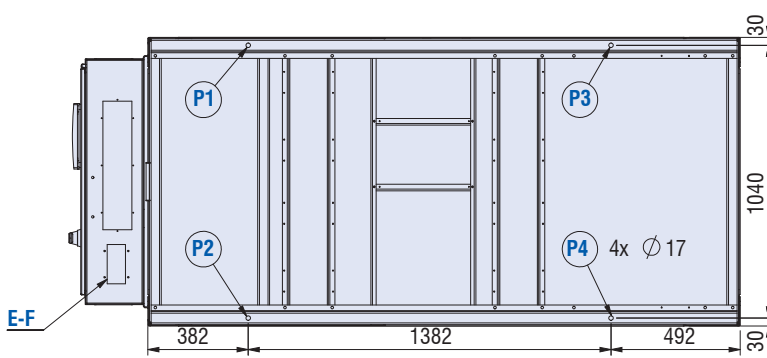

Side view

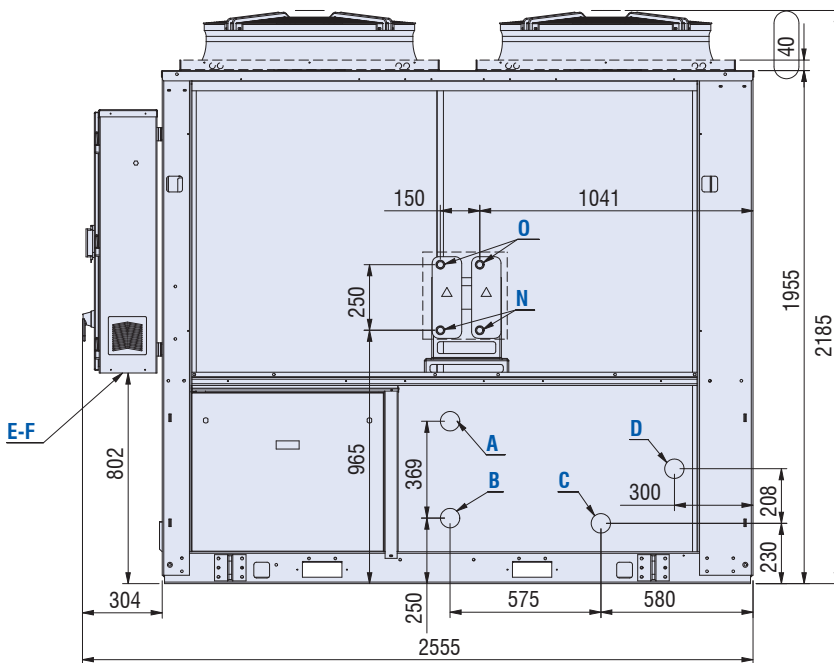

Front view

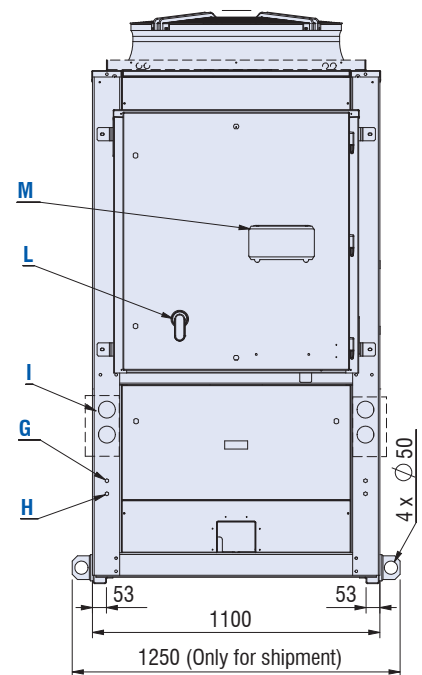

Top view

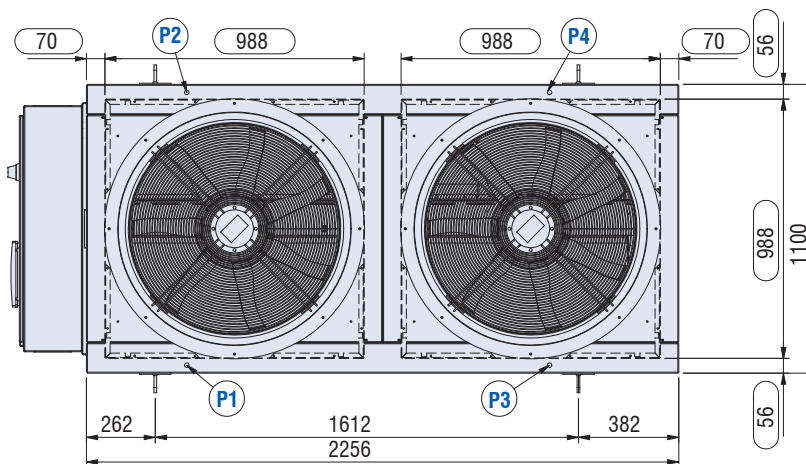

A	Water connection Ø 2 1/2" gas male
B	Water connection Ø 2 1/2" gas male
C	Water connection Ø 2 1/2" gas male
D	Water connection Ø 2 1/2" gas male
E	Electrical auxiliary lines
F	Electrical power supply
G	High pressure tap
H	Low pressure tap
I	Gauge kit (accessory)
L	Main switch
M	Control keypad / display

N	Desuperheater water inlet Ø1" gas male (optional)
O	Desuperheater water outlet Ø1" gas male (optional)
XXX	Only for HPF fan model
P1, P2, P3, P4	AVM position

Hydraulic option	Water in	Water out
STD	A	B
1P/2P/3P	C	B
1P+T/2P+T	C	D